

Spark Plugs & Accessories

FB77WPCC

CHAMPION® Advanced Industrial Spark Plug

Demands for improved engine efficiency and operating conditions within industrial applications are more stringent every year. Despite increased engine load levels, lean air and fuel ratios, and use of new and more corrosive fuels, service life intervals are expected to continue to rise.

CHAMPION's M18 iridium spark plug design has been redeveloped using the RB77WPCC as the baseline. Material upgrades in combination with advanced processing techniques, help answer the call to meet the evolving market demand.

General Features

- Increased service life
- Reduced downtime
- Reduced maintenance requirements and cost
- Improved engine efficiency

Key Features

- 1 High alumina oxide composite insulator
- 2 New Industrial IFISS core seal technology
- 3 Hot lock shell seal
- 4 High temperature-resistant nickel-plated shell
- 5 Thin-walled nickel with top exposed copper center electrode design
- 6 Advanced continuous wave laser at electrode/precious metal contact points
- 7 Iridium (Ir) center electrode
- 8 Grain stabilized platinum (Pt) ground electrode with enlarged cross-section



Call MOTORTECH or your nearest MOTORTECH sales partner for information about the range of application.

■ Spark Plugs & Accessories

Key Design Characteristics

IFISS Core Technology

Industrial Fired-In Suppressor Seal (IFISS) has been specifically designed for industrial applications. Resistance, suppression and sealing capabilities are significantly improved across temperature operating windows, providing a more robust, long-life product.

Electrode Durability

The redesigned firing end (center electrode and ground electrode) includes an enlarged copper-core, larger cross section component, and reoriented electrode surface offering cooler operating temperatures, increased spark efficiency and lengthened service life potential.

Increased Service Life

The new 'FB' design has been validated and field-tested on multiple OEM engine applications with various applied fuels in all regions of the world. Results have consistently shown an increase in plug run-time, hence providing longer service life options to end users.

¹⁾ For cast iron cylinder heads. Please observe the tightening torques rendered by each engine manufacturer.

FB77WPCC

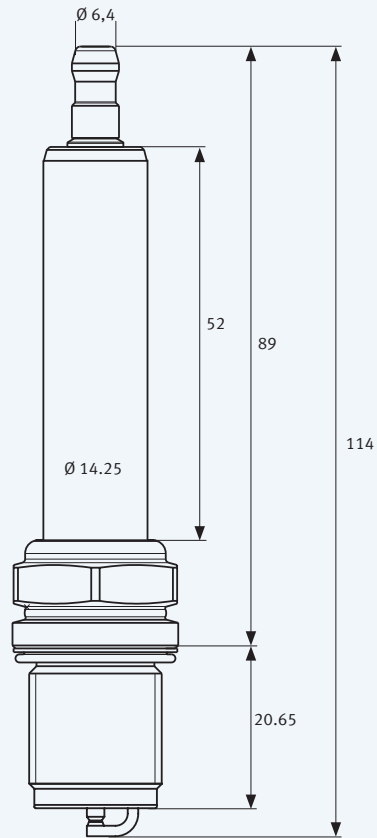

Thread Size:	M18x1.5
Thread Reach:	20.65 mm
Alloy Center/ Ground Electrode:	Iridium / Platinum (Ir/Pt)
HEX:	22.2 mm / 7/8 in
Spark Plug Socket:	07.99.022-3-L
Tightening Torque ¹⁾ :	43 to 52 Nm / 32 to 38 lb-ft
Electrode Gap:	0.30 mm / 0.012 in
Equivalent to:	CATERPILLAR® 301-6663 CHAMPION® RB77WPCC/ KB77WPCC BERU® 18GZ6-77-2/ 18GZ4-77 WAUKESHA® 60999Z/ 69919D

Distributed by:

Copyright

The copyright for all materials used in this MOTORTECH publication is reserved. Any kind of duplication or use of objects such as pictures or texts in other electronic or printed publications without approval by MOTORTECH is not permitted.

Trademark Information

MOTORTECH products and the MOTORTECH logo are registered and/or common law trademarks of MOTORTECH GmbH.

All OEM names and part numbers shown are for reference purposes only. All trademarks, logos and symbols used or shown in this MOTORTECH publication are exclusive objects to the right of their owners and are used for reference purposes only.